

## BBG RENTED EQUIPMENT:

- Coke equipment
- Ice bins behind bars
- Dishwasher behind bar
- ELKO – (Provides cleaning chemicals)
- CO2 tanks provided by Mississippi Welding
- Aramark – mats, linens & hand towels

*Sign + deck West*

*S*



*N  
entrance*

Photo taken by Kevin Ramsell

*East front door*

Located in beautiful Stoughton WI, BBG's sits just off Hwy 51 on the north side of the city. Our style is open, relaxed, friendly and inclusive.

Folks travel from far and wide just to try out our char-grilled Angus beef burgers and "The Best Pizza in Town!" Our thin crust & sauce are made from scratch, and only the freshest ingredients go on our pizzas!

A full line up of fountain drinks, over 16 beers on tap, a vast selection of imports and domestics, and almost any cocktail you can imagine. We have something to quench anyone's thirst!



WISCONSIN REALTORS® ASSOCIATION  
4801 Forest Run Road  
Madison, Wisconsin 53704

**SELLER DISCLOSURE REPORT - COMMERCIAL**

THIS DISCLOSURE REPORT CONCERNS THE REAL PROPERTY LOCATED AT 800 Nygaard Street  
IN THE City (CITY)(VILLAGE) (TOWN) OF Stoughton, COUNTY OF Dane  
STATE OF WISCONSIN. THIS REPORT IS A DISCLOSURE OF THE CONDITION OF THAT  
PROPERTY AS OF August (MONTH) 30th (DAY) 2024 (YEAR).

When listing a property Wis. Admin. Code § REEB 24.07(1)(b) requires licensees to inspect the property and to "make inquiries of the seller on the condition of the structure, mechanical systems and other relevant aspects of the property. The licensee shall request that the seller provide a written response to the licensee's inquiry." This Seller Disclosure Report is a tool designed to help the licensee fulfill this license law duty.

This is not a warranty of any kind by the owner or any agents representing any party in this transaction and is not a substitute for any inspections, testing or warranties that the parties may wish to obtain. This is not a disclosure report required by Wis. Stat. Ch. 709 and the owner is voluntarily providing this information.

**NOTICE TO PARTIES REGARDING ADVICE OR INSPECTIONS**

Real estate licensees may not provide advice or opinions concerning whether or not an item is a defect for the purposes of this report or concerning the legal rights or obligations of parties to a transaction. The parties may wish to obtain professional advice or inspections of the property and to include appropriate provisions in a contract between them with respect to any advice, inspections, defects, or warranties.

**A. OWNER'S INFORMATION**

- A1. In this form, "aware" means the "owner(s)" have notice or knowledge.
- A2. In this form, "defect" means a condition that would have a significant adverse effect on the value of the property; that would significantly impair the health or safety of future occupants of the property; or that if not repaired, removed, or replaced would significantly shorten or adversely affect the expected normal life of the premises.
- A3. In this form, "owner" means the person or persons, entity, or organization that owns the above-described real property.
- A4. The owner represents that to the best of the owner's knowledge, the responses to the following questions have been accurately checked as "yes," "no," or "not applicable (N/A)" to the property being sold. If the owner responds to any question with "yes," the owner shall provide an explanation of the reason why the response to the question is "yes" in the area provided following each group of questions.
- A5. The owner discloses the following information with the knowledge that, even though this is not a warranty, prospective buyers may rely on this information in deciding whether and on what terms to purchase the property. The owner hereby authorizes the owner's agents and the agents of any prospective buyer to provide a copy of this report, and to disclose any information in the report, to any person in connection with any actual or anticipated sale of the property.

**B. STRUCTURAL AND MECHANICAL**

- |   | YES                      | NO                       | N/A                      |
|---|--------------------------|--------------------------|--------------------------|
| B1. Are you aware of defects in the roof?   | <input type="checkbox"/> | <input type="checkbox"/> | <input type="checkbox"/> |
| B2. Are you aware of defects in the electrical system, including defects in solar panels and systems?   | <input type="checkbox"/> | <input type="checkbox"/> | <input type="checkbox"/> |
| B3. Are you aware of defects in part of the plumbing system?  | <input type="checkbox"/> | <input type="checkbox"/> | <input type="checkbox"/> |
| B4. Are you aware of defects in the heating and air conditioning system (including the air filters and humidifiers), fire safety, security or lighting? | <input type="checkbox"/> | <input type="checkbox"/> | <input type="checkbox"/> |
| B5. Are you aware of defects in the basement or foundation (including cracks, seepage, and bulges)?   | <input type="checkbox"/> | <input type="checkbox"/> | <input type="checkbox"/> |
| B6. Are you aware of defects in any structure or structural components on the property (including walls)?   | <input type="checkbox"/> | <input type="checkbox"/> | <input type="checkbox"/> |
| B7. Are you aware of defects in mechanical equipment included in the sale either as fixtures or personal property?                                      | <input type="checkbox"/> | <input type="checkbox"/> | <input type="checkbox"/> |
| B8. Are you aware of rented items located on the property or items affixed to or closely associated with the property?                                  | <input type="checkbox"/> | <input type="checkbox"/> | <input type="checkbox"/> |
| B9. Explanation of "yes" responses _____  |                          |                          |                          |



**C. ENVIRONMENTAL**

- |   | YES                      | NO                       | N/A                      |
|---|--------------------------|--------------------------|--------------------------|
| C1. Are you aware of the presence of unsafe levels of mold?   | <input type="checkbox"/> | <input type="checkbox"/> | <input type="checkbox"/> |
| C2. Are you aware of a defect caused by unsafe concentrations of, or unsafe conditions relating to, radon, radium in water supplies, high voltage electric (100 KV or greater) or steel natural gas transmission lines located on but not directly serving the property, lead in paint, lead in soil, pesticides, or other potentially hazardous or toxic substances on the property? | <input type="checkbox"/> | <input type="checkbox"/> | <input type="checkbox"/> |
| C3. Are you aware of the presence of asbestos or asbestos-containing materials on the property?   | <input type="checkbox"/> | <input type="checkbox"/> | <input type="checkbox"/> |
| C4. Are you aware of the presence of or a defect caused by unsafe concentrations of, unsafe conditions relating to, or the storage of hazardous or toxic substances on neighboring properties?  | <input type="checkbox"/> | <input type="checkbox"/> | <input type="checkbox"/> |
| C5. Are you aware of current or previous termite, powder post beetle, or carpenter ant infestations or defects caused by animal, reptile, or insect infestations, including infestations impacting trees?   | <input type="checkbox"/> | <input type="checkbox"/> | <input type="checkbox"/> |
| C6. Are you aware of water quality issues caused by unsafe concentrations of or unsafe conditions relating to lead?   | <input type="checkbox"/> | <input type="checkbox"/> | <input type="checkbox"/> |
| C7. Are you aware of the manufacture of methamphetamine or other hazardous or toxic substances on the property?   | <input type="checkbox"/> | <input type="checkbox"/> | <input type="checkbox"/> |
| C8. Are you aware of governmental investigation or private assessment/audit (of environmental matters) ever being conducted?  | <input type="checkbox"/> | <input type="checkbox"/> | <input type="checkbox"/> |
| C9. Explanation of "yes" responses _____  |                          |                          |                          |

**D. STORAGE TANKS**

- |   | YES                      | NO                       | N/A                      |
|---|--------------------------|--------------------------|--------------------------|
| D1. Are you aware of underground or aboveground fuel storage tanks on or previously located on the property for storage of flammable or combustible liquids, including but not limited to gasoline and heating oil? | <input type="checkbox"/> | <input type="checkbox"/> | <input type="checkbox"/> |
| D2. Are you aware of defects in the underground or aboveground fuel storage tanks on or previously located on the property?   | <input type="checkbox"/> | <input type="checkbox"/> | <input type="checkbox"/> |
| D3. Explanation of "yes" responses _____  |                          |                          |                          |

**E. TAXES, SPECIAL ASSESSMENTS, PERMITS, ETC.**

- |  | YES                      | NO                       | N/A                      |
|--|--------------------------|--------------------------|--------------------------|
| E1. Have you received notice of property tax increases, other than normal annual increases, or are you aware of a pending property reassessment?   | <input type="checkbox"/> | <input type="checkbox"/> | <input type="checkbox"/> |
| E2. Are you aware that remodeling was done that may increase the property's assessed value?  | <input type="checkbox"/> | <input type="checkbox"/> | <input type="checkbox"/> |
| E3. Are you aware of pending special assessments?  | <input type="checkbox"/> | <input type="checkbox"/> | <input type="checkbox"/> |
| E4. Are you aware that the property is located within a special purpose district, such as a drainage district, that has the authority to impose assessments against the real property located within the district?                               | <input type="checkbox"/> | <input type="checkbox"/> | <input type="checkbox"/> |
| E5. Are you aware of any proposed construction of a public project that may affect the use of the property?  | <input type="checkbox"/> | <input type="checkbox"/> | <input type="checkbox"/> |
| E6. Are you aware of any remodeling, replacements, or repairs affecting the property's structure or mechanical systems that were done or additions to this property that were made during your period of ownership without the required permits? | <input type="checkbox"/> | <input type="checkbox"/> | <input type="checkbox"/> |
| E7. Are you aware of any land division involving the property for which a required state or local permit was not obtained?   | <input type="checkbox"/> | <input type="checkbox"/> | <input type="checkbox"/> |
| E8. Explanation of "yes" responses _____   |                          |                          |                          |

**F. LAND USE**

- |  | YES                      | NO                       | N/A                      |
|--|--------------------------|--------------------------|--------------------------|
| F1. Are you aware of any zoning code violations with respect to the property?  | <input type="checkbox"/> | <input type="checkbox"/> | <input type="checkbox"/> |
| F2. Are you aware of the property or any portion of the property being located in a floodplain, wetland, or shoreland zoning area, or of flooding, drainage problems, standing water or other water problems affecting the property? | <input type="checkbox"/> | <input type="checkbox"/> | <input type="checkbox"/> |
| F3. Are you aware of nonconforming uses of the property or nonconforming structures on the property?   | <input type="checkbox"/> | <input type="checkbox"/> | <input type="checkbox"/> |
| F4. Are you aware of conservation easements on the property?   | <input type="checkbox"/> | <input type="checkbox"/> | <input type="checkbox"/> |
| F5. Are you aware of restrictive covenants or deed restrictions on the property?   | <input type="checkbox"/> | <input type="checkbox"/> | <input type="checkbox"/> |
| F6. Are you aware of nonowners having rights to use part of the property, including, but not limited to, rights-of-way and easements other than recorded utility easements?  | <input type="checkbox"/> | <input type="checkbox"/> | <input type="checkbox"/> |



- |  | YES                      | NO                       | N/A                      |
|--|--------------------------|--------------------------|--------------------------|
| F7. Are you aware of the property being subject to a mitigation plan required under administrative rules of the Wisconsin Department of Natural Resources related to county shoreland zoning ordinances?   | <input type="checkbox"/> | <input type="checkbox"/> | <input type="checkbox"/> |
| F8. <u>Use Value.</u>  |                          |                          |                          |
| a. Are you aware of all or part of the property having been assessed as agricultural land under Wis. Stat. s. 70.32 (2r) (use value assessment)?   | <input type="checkbox"/> | <input type="checkbox"/> | <input type="checkbox"/> |
| b. Are you aware of the property having been assessed a use-value assessment conversion charge relating to this property? (Wis. Stat. s. 74.485 (2))   | <input type="checkbox"/> | <input type="checkbox"/> | <input type="checkbox"/> |
| c. Are you aware of the payment of a use-value assessment conversion charge having been deferred relating to this property? (Wis. Stat. s. 74.485 (4))   | <input type="checkbox"/> | <input type="checkbox"/> | <input type="checkbox"/> |
| F9. Is all or part of the property subject to or in violation of a farmland preservation agreement?  | <input type="checkbox"/> | <input type="checkbox"/> | <input type="checkbox"/> |
| F10. Is all or part of the property subject to, enrolled in, or in violation of the Forest Crop Law, Managed Forest Law, the Conservation Reserve Program, or a comparable program?  | <input type="checkbox"/> | <input type="checkbox"/> | <input type="checkbox"/> |
| F11. Are you aware of a dam that is totally or partially located on the property or that an ownership in a dam that is not located on the property will be transferred with the property because it is owned collectively by members of a homeowners' association, lake district, or similar group? (If "yes," contact the Wisconsin Department of Natural Resources to find out if dam transfer requirements or agency orders apply.) | <input type="checkbox"/> | <input type="checkbox"/> | <input type="checkbox"/> |
| F12. Are you aware of boundary or lot line disputes, encroachments, or encumbrances affecting the property?  | <input type="checkbox"/> | <input type="checkbox"/> | <input type="checkbox"/> |
| F12a. Are you aware of any private road agreements or shared driveway agreements relating to the property?   | <input type="checkbox"/> | <input type="checkbox"/> | <input type="checkbox"/> |
| F13. Are you aware there is not legal access to the property?  | <input type="checkbox"/> | <input type="checkbox"/> | <input type="checkbox"/> |
| F14. Are you aware of federal, state, or local regulations requiring repairs, alterations, or corrections of an existing condition? This may include items such as orders to correct building code violations.   | <input type="checkbox"/> | <input type="checkbox"/> | <input type="checkbox"/> |
| F15. Are you aware of a pier attached to the property that is not in compliance with state or local pier regulations? See <a href="#">do you have a pier?</a> for more information.  | <input type="checkbox"/> | <input type="checkbox"/> | <input type="checkbox"/> |
| F16. Are you aware of one or more burial sites or archeological artifacts on the property? (For information regarding the presence, preservation, and potential disturbance of burial sites, contact the Wisconsin Historical Society at 800-342-7834 or <a href="http://www.wishist.org/burial-information">www.wishist.org/burial-information</a> ).   | <input type="checkbox"/> | <input type="checkbox"/> | <input type="checkbox"/> |
| F17. Explanation of "yes" responses _____  |                          |                          |                          |

**G. ADDITIONAL INFORMATION**

- |   | YES                      | NO                       | N/A                      |
|---|--------------------------|--------------------------|--------------------------|
| G1. Are you aware of a structure on the property that is designated as a historic building or that all or any part of the property is in a historic district?   | <input type="checkbox"/> | <input type="checkbox"/> | <input type="checkbox"/> |
| G2. Are you aware of any agreements that bind subsequent owners of the property, such as a lease agreement or an extension of credit from an electric cooperative?  | <input type="checkbox"/> | <input type="checkbox"/> | <input type="checkbox"/> |
| G2a. Are you aware of any right of first refusal, recorded or not, on all or any portion of the property?   | <input type="checkbox"/> | <input type="checkbox"/> | <input type="checkbox"/> |
| G3. Are you aware of defects in a well on the property or in a well that serves the property, including unsafe well water?  | <input type="checkbox"/> | <input type="checkbox"/> | <input type="checkbox"/> |
| G4. Are you aware of a joint well serving the property including any defect related to a joint well serving the property?   | <input type="checkbox"/> | <input type="checkbox"/> | <input type="checkbox"/> |
| G5. Are you aware that a septic system or other private sanitary disposal system serves the property including defects in the septic system or other private sanitary disposal system on the property or any out-of-service septic system that serves the property and that is not closed or abandoned according to applicable regulations? | <input type="checkbox"/> | <input type="checkbox"/> | <input type="checkbox"/> |
| G6. Are you aware of an "LP" tank on the property, including defects? (If "yes," specify in the additional information space whether the owner of the property either owns or leases the tank.)   | <input type="checkbox"/> | <input type="checkbox"/> | <input type="checkbox"/> |
| G7. Are you aware of material damage from fire, wind, floods, earthquake, expansive soils, erosion or landslides?   | <input type="checkbox"/> | <input type="checkbox"/> | <input type="checkbox"/> |
| G8. Are you aware of nearby airports, freeways, railroads or landfills, or significant odor, noise, water intrusion or other irritants emanating from neighboring property?   | <input type="checkbox"/> | <input type="checkbox"/> | <input type="checkbox"/> |
| G9. Are you aware of any shared usages such as shared fences, walls, driveways, or signage, or any defect relating to the shared use?   | <input type="checkbox"/> | <input type="checkbox"/> | <input type="checkbox"/> |
| G10. Are you aware of leased parking?   | <input type="checkbox"/> | <input type="checkbox"/> | <input type="checkbox"/> |
| G10a. Does the property currently have internet service?<br>If so, who is your provider? _____  | <input type="checkbox"/> | <input type="checkbox"/> | <input type="checkbox"/> |
| G10b. Does the property have an electric vehicle charging system and station or installed wiring for a future system or station?<br>Is the system or station affixed to the property?   | <input type="checkbox"/> | <input type="checkbox"/> | <input type="checkbox"/> |
| G10c. Does the property have accessibility features? See <a href="https://www.ada.gov/resources/title-iii-primer/">https://www.ada.gov/resources/title-iii-primer/</a> .  | <input type="checkbox"/> | <input type="checkbox"/> | <input type="checkbox"/> |
| G11. Are you aware of other defects affecting the property?   | <input type="checkbox"/> | <input type="checkbox"/> | <input type="checkbox"/> |
| G12. The owner has owned the property for _____ years.  | <input type="checkbox"/> | <input type="checkbox"/> | <input type="checkbox"/> |



G13. Explanation of "yes" responses \_\_\_\_\_  
\_\_\_\_\_  
\_\_\_\_\_  
\_\_\_\_\_

Note: Any sales contract provision requiring inspection of a residential dumbwaiter or elevator must be performed by a state-licensed elevator inspector.

**OWNER'S CERTIFICATION**

The owner certifies that the information in this report is true and correct to the best of the owner's knowledge as of the date on which the owner signs this report.

Entity Name (if any): Banushis LLC dba BBG

Name & Title of Authorized Representative Signing for Entity: \_\_\_\_\_

Authorized Signature for Entity: \_\_\_\_\_ Date 08-20-2024

Owner [Signature] Signed by: \_\_\_\_\_ Date 08-20-2024  
1CDB4B5EA25D4C4...

Owner \_\_\_\_\_ DocuSigned by: Karim Abrouq Date 18-20-2024  
B89A5026FE3F452...

Owner \_\_\_\_\_ Date \_\_\_\_\_

Owner \_\_\_\_\_ Date \_\_\_\_\_

Owner \_\_\_\_\_ Date \_\_\_\_\_

**CERTIFICATION BY PERSON SUPPLYING INFORMATION**

A person other than the owner certifies that the person supplied information on which the owner relied for this report and that the information is true and correct to the best of the person's knowledge as of the date on which the person signs this report.

Person \_\_\_\_\_ Items \_\_\_\_\_ Date \_\_\_\_\_

Person \_\_\_\_\_ Items \_\_\_\_\_ Date \_\_\_\_\_

**BUYER'S ACKNOWLEDGEMENT**

The prospective buyer acknowledges that technical knowledge such as that acquired by professional inspectors may be required to detect certain defects such as the presence of asbestos, building code violations, and floodplain status.

I acknowledge receipt of a copy of this statement.

Entity Name (if any): \_\_\_\_\_

Name & Title of Authorized Representative Signing for Entity: \_\_\_\_\_

Authorized Signature for Entity: \_\_\_\_\_ Date \_\_\_\_\_

Prospective buyer \_\_\_\_\_ Date \_\_\_\_\_

Prospective buyer \_\_\_\_\_ Date \_\_\_\_\_

Prospective buyer \_\_\_\_\_ Date \_\_\_\_\_

Prospective buyer \_\_\_\_\_ Date \_\_\_\_\_

Prospective buyer \_\_\_\_\_ Date \_\_\_\_\_









**DIMENSION IV  
MADISON**

Architecture  
Engineering  
Interior Design

300 Wisconsin Street, Suite 601  
Madison, WI 53703  
Phone (608) 278-4444 Fax (608) 278-4445

**BROUX HOUSE**

800 NYGAARD STREET  
STOUGHTON, WISCONSIN

**Bauer & Raether Builders**

DATE OF ISSUE: April 8, 2005

PROJECT #:

**FLOOR PLANS  
A1.0**

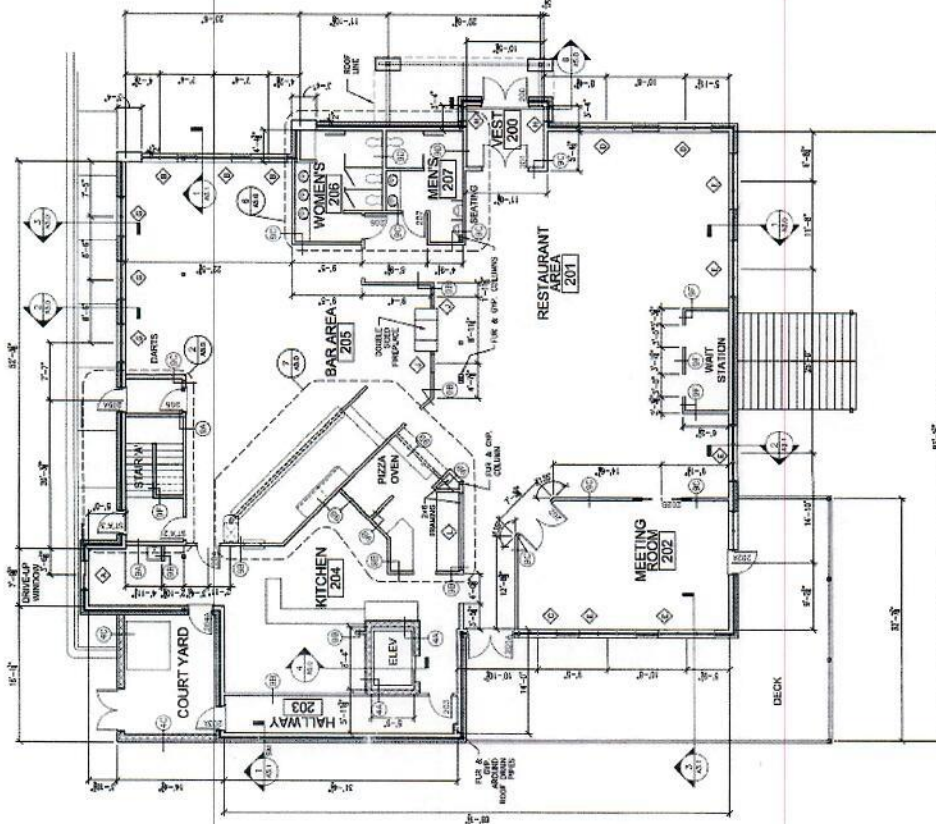

2 UPPER FLOOR LEVEL

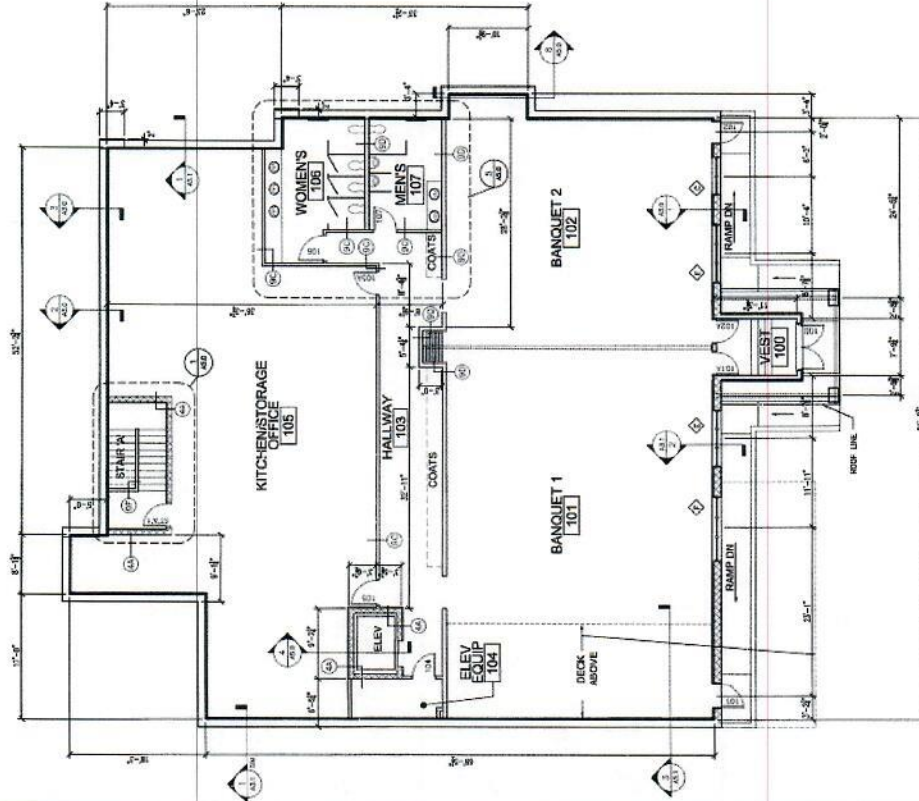

1 LOWER FLOOR LEVEL



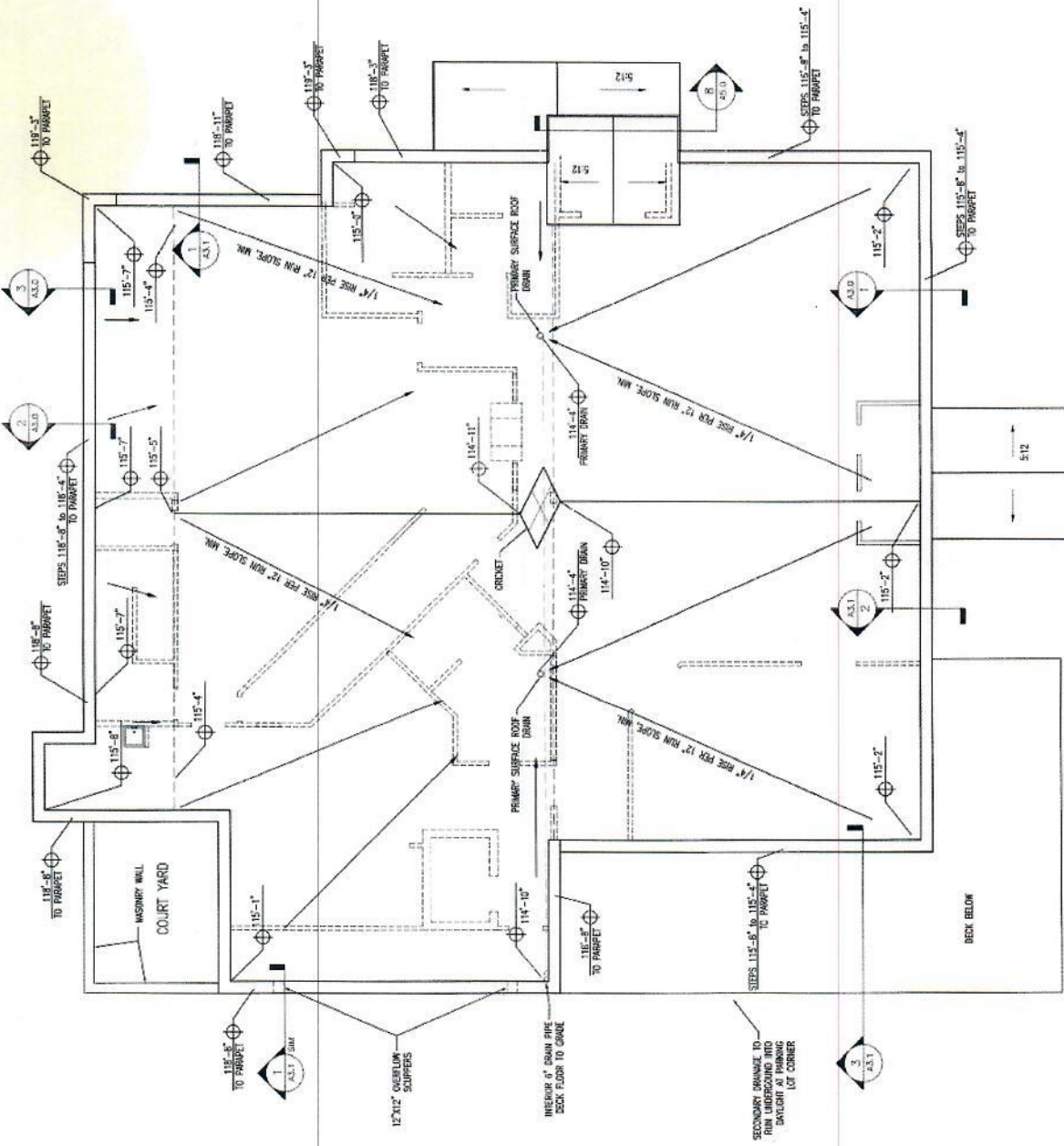

**1** ROOF PLAN









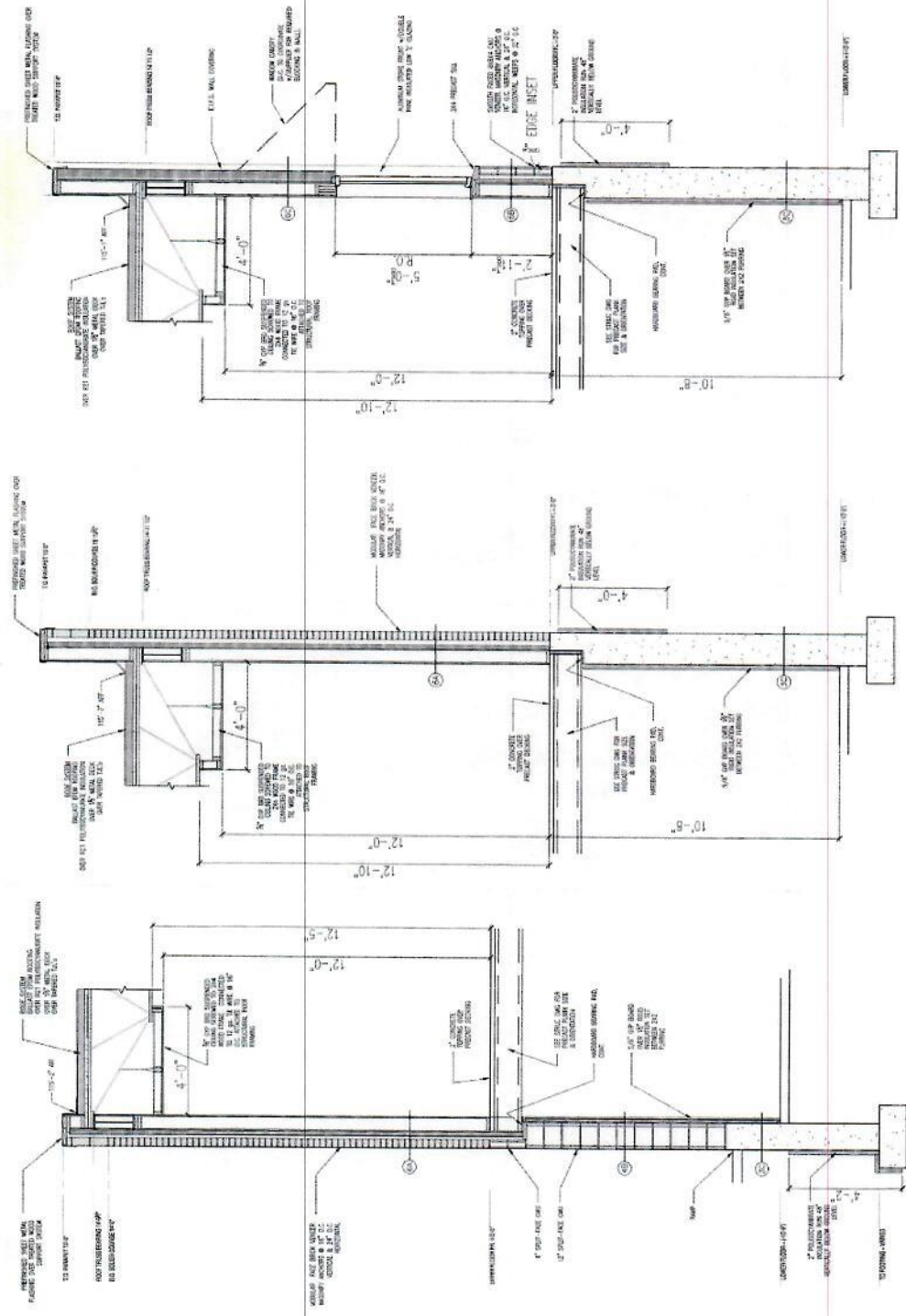

**2 EXTERIOR WALL SECTION CUT**

**3 EXTERIOR WALL SECTION CUT**















WINDOW SCHEDULE

MARK	APPROX. GRID SIZE	STYLE	GLAZING
A	4'-0" x 4'-0" x 8'-0"	FIXED, ALUM. FINISH	CL-1
B	4'-0" x 4'-0" x 8'-0"	FIXED, ALUM. FINISH	CL-1
C	4'-0" x 4'-0" x 8'-0"	FIXED, ALUM. FINISH	CL-1
D	4'-0" x 4'-0" x 8'-0"	FIXED, ALUM. FINISH	CL-1
E	4'-0" x 4'-0" x 8'-0"	FIXED, ALUM. FINISH	CL-1
F	4'-0" x 4'-0" x 8'-0"	FIXED, ALUM. FINISH	CL-1
G	4'-0" x 4'-0" x 8'-0"	FIXED, ALUM. FINISH	CL-1
H	4'-0" x 4'-0" x 8'-0"	FIXED, ALUM. FINISH	CL-1
I	4'-0" x 4'-0" x 8'-0"	FIXED, ALUM. FINISH	CL-1
J	4'-0" x 4'-0" x 8'-0"	FIXED, ALUM. FINISH	CL-1
K	4'-0" x 4'-0" x 8'-0"	FIXED, ALUM. FINISH	CL-1
L	4'-0" x 4'-0" x 8'-0"	FIXED, ALUM. FINISH	CL-1

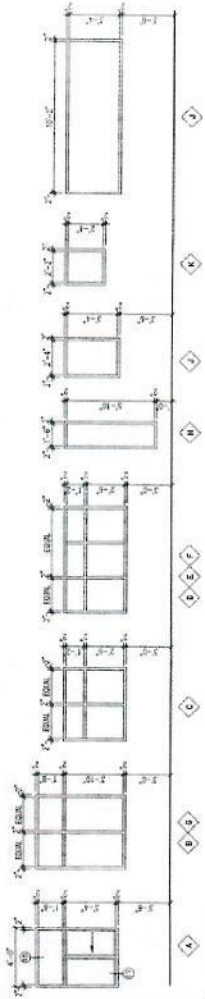

1 WINDOW ELEVATIONS

**DIMENSION IV**  
**MADISON**

Architecture  
Engineering  
Interior Design  
313 First Avenue, Suite 200  
Madison, WI 53702  
Phone: (608) 278-4444 Fax: (608) 278-4440

GLASS TYPE SCHED

CL-1	1/4" INSULATED GLAZING UNIT (IGU) WITH 1/2" CLEAR GLASS
CL-2	1/4" INSULATED GLAZING UNIT (IGU) WITH 1/2" CLEAR GLASS AND 1/2" CLEAR GLASS
CL-3	1/4" INSULATED GLAZING UNIT (IGU) WITH 1/2" CLEAR GLASS AND 1/2" CLEAR GLASS
CL-4	1/4" INSULATED GLAZING UNIT (IGU) WITH 1/2" CLEAR GLASS AND 1/2" CLEAR GLASS

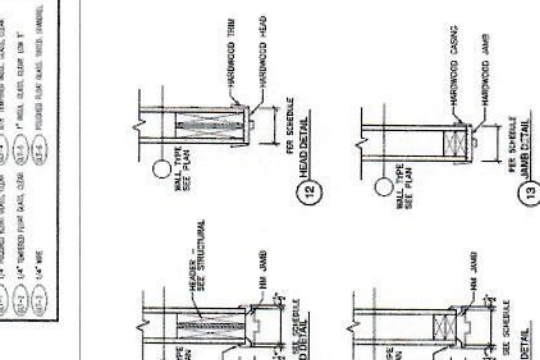
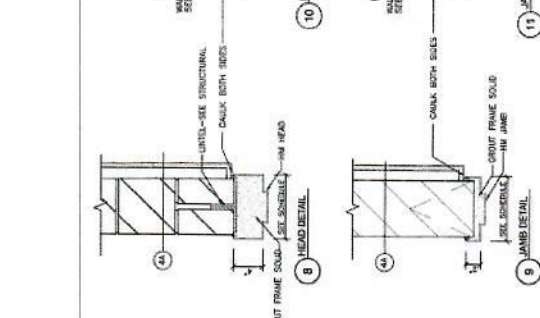
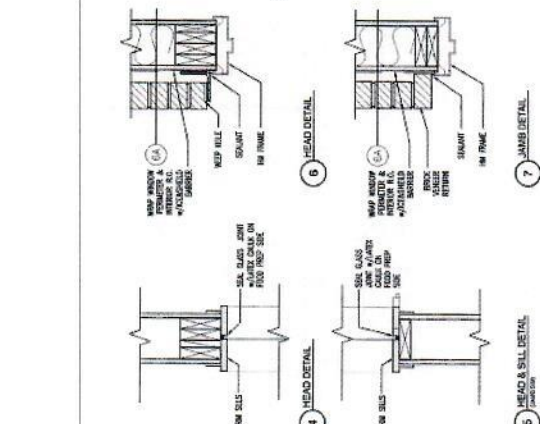
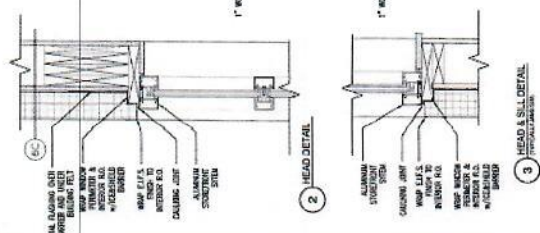

**BROUX HOUSE**  
800 RYNGAARD STREET  
STOUGHTON, WISCONSIN

**Bauer & Raether Builders**  
DATE OF ISSUE: April 13, 2010  
PROJECT #: 04104  
**WINDOW SCHEDULE & DETAILS**  
**A6.1**

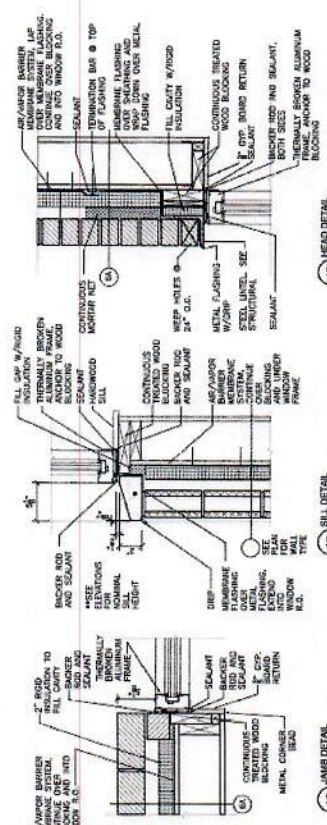







**BROUX HOUSE**

800 NYGAARD STREET  
 STOUTTOWN, WISCONSIN

**Bauer & Raether Builders**

DATE OF ISSUE: April 5, 2006

PROJECT #: \_\_\_\_\_

**FOUNDATION PLAN**

**S1.0**

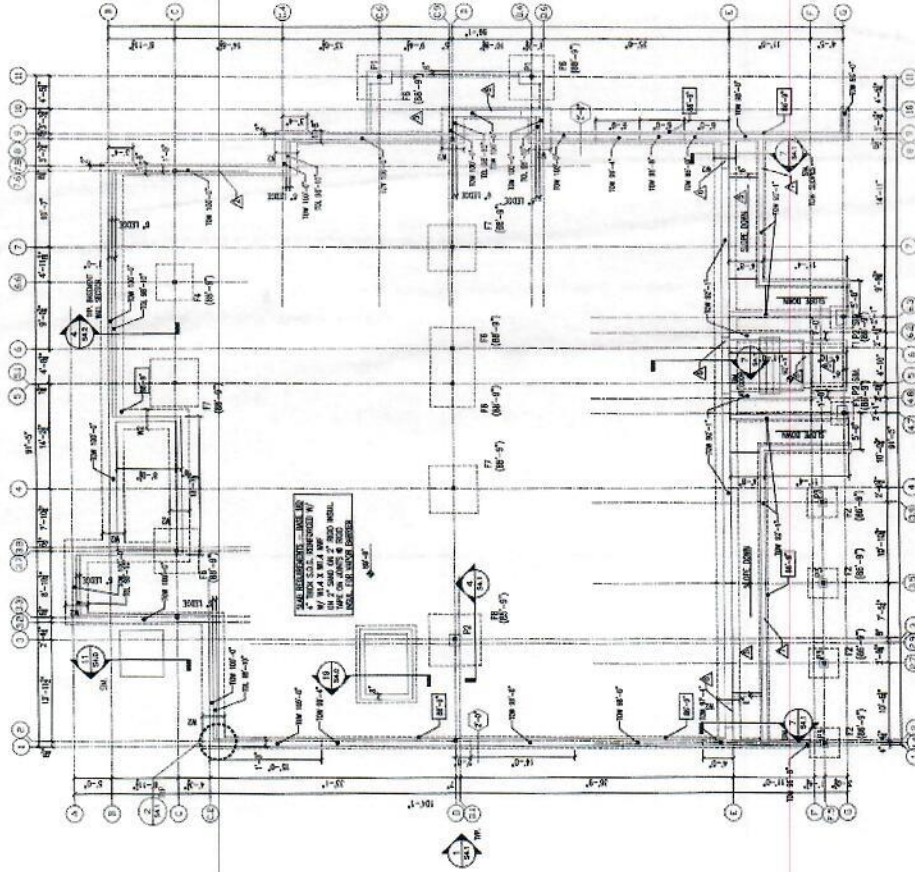

**PIER SCHEDULE**

MARK	WIDTH	LENGTH	REINFORCEMENT	REMARKS
P1	3'-0"	1'-0"	(6) #6 VERT. @ 12" O.C. VERT. W/ (2) #5 @ 3'-0" O.C. @ TOP & BOTTOM OF PIER	
P2	18"	18"	(4) #6 VERT. @ 12" O.C. @ 12" O.C. VERT. TOP OF PIER @ 30'-0"	
P3	12"	12"	(4) #6 VERT. @ 12" O.C. @ 12" O.C. VERT. TOP OF PIER @ 12"	

**FOOTING SCHEDULE**

MARK	WIDTH	LENGTH	DEPTH	REINFORCEMENT	REMARKS
F1	2'-0"	3'-0"	1'-0"	(8) # 17.0C. DA. WAF	
F2	4'-0"	4'-0"	1'-0"	(8) # 17.0C. DA. WAF	
F3	4'-0"	4'-0"	1'-0"	(7) # 6 @ 8" O.C. DA. WAF	
F4	5'-0"	5'-0"	1'-0"	(8) # 6 @ 12" O.C. DA. WAF	
F5	5'-0"	5'-0"	1'-0"	(8) # 6 @ 12" O.C. DA. WAF	
F6	5'-0"	5'-0"	1'-0"	(8) # 6 @ 12" O.C. DA. WAF	
F7	5'-0"	5'-0"	1'-0"	(8) # 6 @ 12" O.C. DA. WAF	
F8	5'-0"	5'-0"	1'-0"	(8) # 6 @ 12" O.C. DA. WAF	
F9	5'-0"	5'-0"	1'-0"	(8) # 6 @ 12" O.C. DA. WAF	
F10	5'-0"	5'-0"	1'-0"	(8) # 6 @ 12" O.C. DA. WAF	
F11	5'-0"	5'-0"	1'-0"	(8) # 6 @ 12" O.C. DA. WAF	
F12	5'-0"	5'-0"	1'-0"	(8) # 6 @ 12" O.C. DA. WAF	
F13	5'-0"	5'-0"	1'-0"	(8) # 6 @ 12" O.C. DA. WAF	
F14	5'-0"	5'-0"	1'-0"	(8) # 6 @ 12" O.C. DA. WAF	
F15	5'-0"	5'-0"	1'-0"	(8) # 6 @ 12" O.C. DA. WAF	
F16	5'-0"	5'-0"	1'-0"	(8) # 6 @ 12" O.C. DA. WAF	
F17	5'-0"	5'-0"	1'-0"	(8) # 6 @ 12" O.C. DA. WAF	
F18	5'-0"	5'-0"	1'-0"	(8) # 6 @ 12" O.C. DA. WAF	
F19	5'-0"	5'-0"	1'-0"	(8) # 6 @ 12" O.C. DA. WAF	
F20	5'-0"	5'-0"	1'-0"	(8) # 6 @ 12" O.C. DA. WAF	
F21	5'-0"	5'-0"	1'-0"	(8) # 6 @ 12" O.C. DA. WAF	
F22	5'-0"	5'-0"	1'-0"	(8) # 6 @ 12" O.C. DA. WAF	
F23	5'-0"	5'-0"	1'-0"	(8) # 6 @ 12" O.C. DA. WAF	
F24	5'-0"	5'-0"	1'-0"	(8) # 6 @ 12" O.C. DA. WAF	
F25	5'-0"	5'-0"	1'-0"	(8) # 6 @ 12" O.C. DA. WAF	
F26	5'-0"	5'-0"	1'-0"	(8) # 6 @ 12" O.C. DA. WAF	
F27	5'-0"	5'-0"	1'-0"	(8) # 6 @ 12" O.C. DA. WAF	
F28	5'-0"	5'-0"	1'-0"	(8) # 6 @ 12" O.C. DA. WAF	
F29	5'-0"	5'-0"	1'-0"	(8) # 6 @ 12" O.C. DA. WAF	
F30	5'-0"	5'-0"	1'-0"	(8) # 6 @ 12" O.C. DA. WAF	
F31	5'-0"	5'-0"	1'-0"	(8) # 6 @ 12" O.C. DA. WAF	
F32	5'-0"	5'-0"	1'-0"	(8) # 6 @ 12" O.C. DA. WAF	
F33	5'-0"	5'-0"	1'-0"	(8) # 6 @ 12" O.C. DA. WAF	
F34	5'-0"	5'-0"	1'-0"	(8) # 6 @ 12" O.C. DA. WAF	
F35	5'-0"	5'-0"	1'-0"	(8) # 6 @ 12" O.C. DA. WAF	
F36	5'-0"	5'-0"	1'-0"	(8) # 6 @ 12" O.C. DA. WAF	
F37	5'-0"	5'-0"	1'-0"	(8) # 6 @ 12" O.C. DA. WAF	
F38	5'-0"	5'-0"	1'-0"	(8) # 6 @ 12" O.C. DA. WAF	
F39	5'-0"	5'-0"	1'-0"	(8) # 6 @ 12" O.C. DA. WAF	
F40	5'-0"	5'-0"	1'-0"	(8) # 6 @ 12" O.C. DA. WAF	
F41	5'-0"	5'-0"	1'-0"	(8) # 6 @ 12" O.C. DA. WAF	
F42	5'-0"	5'-0"	1'-0"	(8) # 6 @ 12" O.C. DA. WAF	
F43	5'-0"	5'-0"	1'-0"	(8) # 6 @ 12" O.C. DA. WAF	
F44	5'-0"	5'-0"	1'-0"	(8) # 6 @ 12" O.C. DA. WAF	
F45	5'-0"	5'-0"	1'-0"	(8) # 6 @ 12" O.C. DA. WAF	
F46	5'-0"	5'-0"	1'-0"	(8) # 6 @ 12" O.C. DA. WAF	
F47	5'-0"	5'-0"	1'-0"	(8) # 6 @ 12" O.C. DA. WAF	
F48	5'-0"	5'-0"	1'-0"	(8) # 6 @ 12" O.C. DA. WAF	
F49	5'-0"	5'-0"	1'-0"	(8) # 6 @ 12" O.C. DA. WAF	
F50	5'-0"	5'-0"	1'-0"	(8) # 6 @ 12" O.C. DA. WAF	
F51	5'-0"	5'-0"	1'-0"	(8) # 6 @ 12" O.C. DA. WAF	
F52	5'-0"	5'-0"	1'-0"	(8) # 6 @ 12" O.C. DA. WAF	
F53	5'-0"	5'-0"	1'-0"	(8) # 6 @ 12" O.C. DA. WAF	
F54	5'-0"	5'-0"	1'-0"	(8) # 6 @ 12" O.C. DA. WAF	
F55	5'-0"	5'-0"	1'-0"	(8) # 6 @ 12" O.C. DA. WAF	
F56	5'-0"	5'-0"	1'-0"	(8) # 6 @ 12" O.C. DA. WAF	
F57	5'-0"	5'-0"	1'-0"	(8) # 6 @ 12" O.C. DA. WAF	
F58	5'-0"	5'-0"	1'-0"	(8) # 6 @ 12" O.C. DA. WAF	
F59	5'-0"	5'-0"	1'-0"	(8) # 6 @ 12" O.C. DA. WAF	
F60	5'-0"	5'-0"	1'-0"	(8) # 6 @ 12" O.C. DA. WAF	
F61	5'-0"	5'-0"	1'-0"	(8) # 6 @ 12" O.C. DA. WAF	
F62	5'-0"	5'-0"	1'-0"	(8) # 6 @ 12" O.C. DA. WAF	
F63	5'-0"	5'-0"	1'-0"	(8) # 6 @ 12" O.C. DA. WAF	
F64	5'-0"	5'-0"	1'-0"	(8) # 6 @ 12" O.C. DA. WAF	
F65	5'-0"	5'-0"	1'-0"	(8) # 6 @ 12" O.C. DA. WAF	
F66	5'-0"	5'-0"	1'-0"	(8) # 6 @ 12" O.C. DA. WAF	
F67	5'-0"	5'-0"	1'-0"	(8) # 6 @ 12" O.C. DA. WAF	
F68	5'-0"	5'-0"	1'-0"	(8) # 6 @ 12" O.C. DA. WAF	
F69	5'-0"	5'-0"	1'-0"	(8) # 6 @ 12" O.C. DA. WAF	
F70	5'-0"	5'-0"	1'-0"	(8) # 6 @ 12" O.C. DA. WAF	
F71	5'-0"	5'-0"	1'-0"	(8) # 6 @ 12" O.C. DA. WAF	
F72	5'-0"	5'-0"	1'-0"	(8) # 6 @ 12" O.C. DA. WAF	
F73	5'-0"	5'-0"	1'-0"	(8) # 6 @ 12" O.C. DA. WAF	
F74	5'-0"	5'-0"	1'-0"	(8) # 6 @ 12" O.C. DA. WAF	
F75	5'-0"	5'-0"	1'-0"	(8) # 6 @ 12" O.C. DA. WAF	
F76	5'-0"	5'-0"	1'-0"	(8) # 6 @ 12" O.C. DA. WAF	
F77	5'-0"	5'-0"	1'-0"	(8) # 6 @ 12" O.C. DA. WAF	
F78	5'-0"	5'-0"	1'-0"	(8) # 6 @ 12" O.C. DA. WAF	
F79	5'-0"	5'-0"	1'-0"	(8) # 6 @ 12" O.C. DA. WAF	
F80	5'-0"	5'-0"	1'-0"	(8) # 6 @ 12" O.C. DA. WAF	
F81	5'-0"	5'-0"	1'-0"	(8) # 6 @ 12" O.C. DA. WAF	
F82	5'-0"	5'-0"	1'-0"	(8) # 6 @ 12" O.C. DA. WAF	
F83	5'-0"	5'-0"	1'-0"	(8) # 6 @ 12" O.C. DA. WAF	
F84	5'-0"	5'-0"	1'-0"	(8) # 6 @ 12" O.C. DA. WAF	
F85	5'-0"	5'-0"	1'-0"	(8) # 6 @ 12" O.C. DA. WAF	
F86	5'-0"	5'-0"	1'-0"	(8) # 6 @ 12" O.C. DA. WAF	
F87	5'-0"	5'-0"	1'-0"	(8) # 6 @ 12" O.C. DA. WAF	
F88	5'-0"	5'-0"	1'-0"	(8) # 6 @ 12" O.C. DA. WAF	
F89	5'-0"	5'-0"	1'-0"	(8) # 6 @ 12" O.C. DA. WAF	
F90	5'-0"	5'-0"	1'-0"	(8) # 6 @ 12" O.C. DA. WAF	
F91	5'-0"	5'-0"	1'-0"	(8) # 6 @ 12" O.C. DA. WAF	
F92	5'-0"	5'-0"	1'-0"	(8) # 6 @ 12" O.C. DA. WAF	
F93	5'-0"	5'-0"	1'-0"	(8) # 6 @ 12" O.C. DA. WAF	
F94	5'-0"	5'-0"	1'-0"	(8) # 6 @ 12" O.C. DA. WAF	
F95	5'-0"	5'-0"	1'-0"	(8) # 6 @ 12" O.C. DA. WAF	
F96	5'-0"	5'-0"	1'-0"	(8) # 6 @ 12" O.C. DA. WAF	
F97	5'-0"	5'-0"	1'-0"	(8) # 6 @ 12" O.C. DA. WAF	
F98	5'-0"	5'-0"	1'-0"	(8) # 6 @ 12" O.C. DA. WAF	
F99	5'-0"	5'-0"	1'-0"	(8) # 6 @ 12" O.C. DA. WAF	
F100	5'-0"	5'-0"	1'-0"	(8) # 6 @ 12" O.C. DA. WAF	

- FOUNDATION PLAN NOTES:**
- ▲ 12" O.C. IN FACE WALLS
  - ▲ ALL SUMP FOOTINGS ARE W/ UMB.
  - ▲ SEE W. 11. & 10/24/04 FOR THE SIZES ON CIVIL CONTS.
  - ▲ SEE S1.1 FOR ADDITIONAL REINFORCEMENT SCHEDULES
  - ▲ REVISIONS TO O.C. IN FACE WALLS
  - ▲ THE EXTERIOR CONCRETE SLABS ARE 4" THICK
  - ▲ W/ #4 @ 12" O.C. DA. WAF
  - ▲ DROP TOP OF WALL IF THE # STRUTTING
  - ▲ 12" O.C. IN FACE OF #4 @ 12" O.C. DA. WAF CHECKED IN WALLS
  - ▲ WALLS TO FINISH







# DIMENSION IV MADISON

Architecture  
Engineering  
Interior Design

33 West Academy Hwy, Suite 201  
Madison, WI 53703  
Phone: (608) 255-2444 Fax: (608) 255-4145

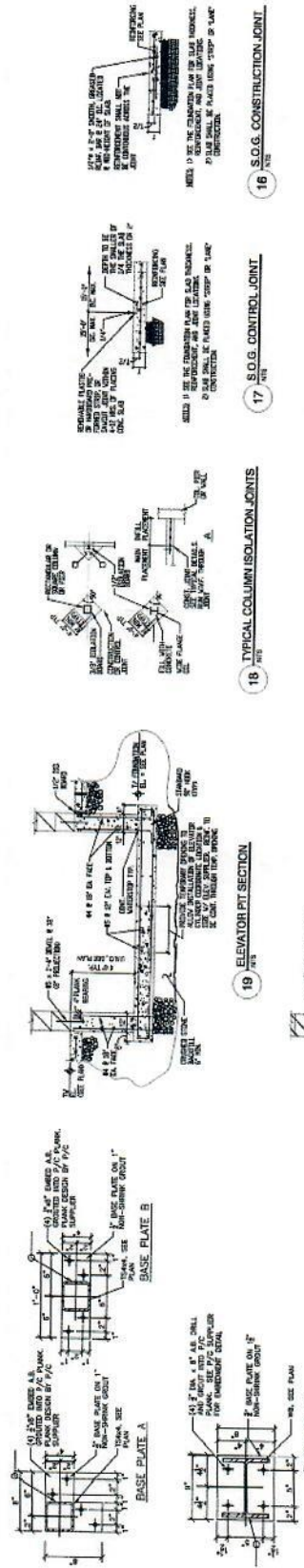

# BROUX HOUSE

800 NYGAARD STREET  
STOUGHTON, WISCONSIN

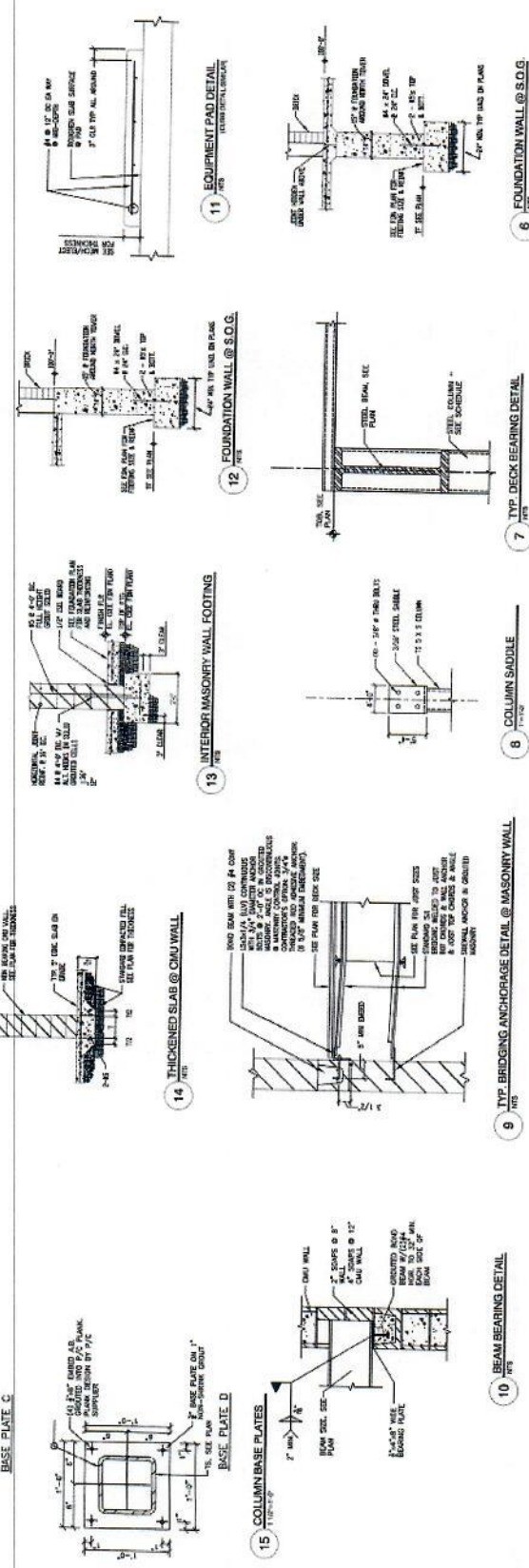

Bauer & Raether Builders  
DATE OF ISSUE: April 3, 2008

PROJECT #:  
DRAWING #:

## STRUCTURAL DETAILS

# S4.0

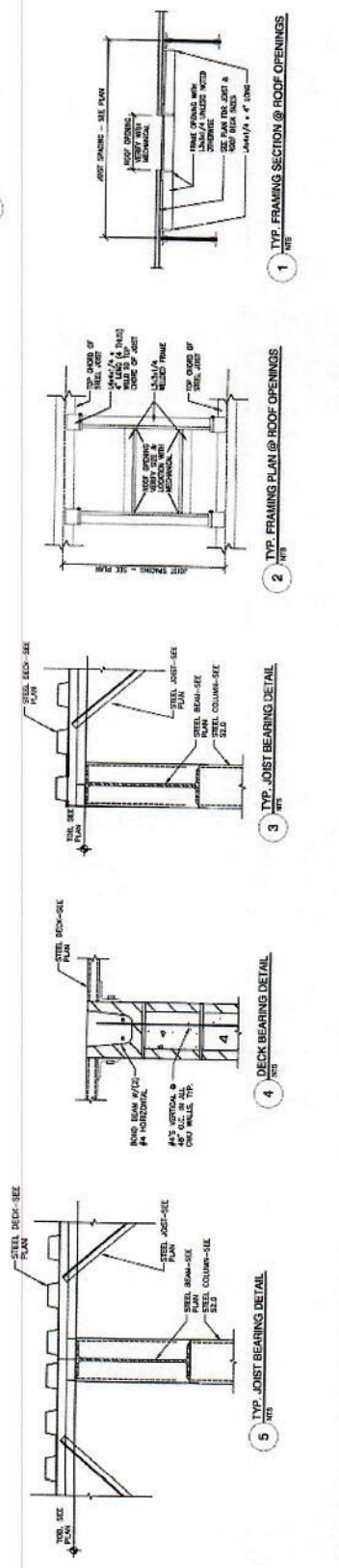



**BROUX HOUSE**  
 800 HINGAARD STREET  
 STOUTINGTON, WISCONSIN

**Bauer & Raether Builders**  
 DATE OF ISSUE: April 5, 2005

PROJECT # \_\_\_\_\_  
 DRAWING NO. \_\_\_\_\_

**STRUCTURAL DETAILS**

**S4.0**

